



EARTHING PROTECTION

*MATERIALS
FOR EARTHING
PROTECTION
SYSTEMS*



EARTHING PROTECTION

EARTHING SYSTEMS

Although many elements as solid plates, radial strips, buried conductors, etc. are used as earthing electrodes, we refer here only to the deep driven rod electrodes because these are the most widely used due that this kind of electrodes are highly efficient and comparatively low cost in installation.

The rod electrodes are driven into soil by hammering them so the contact resistance between the earth rod and the adjacent earth is negligible without needing of additional packing and the connection of the earth conductor is easily checkable at any time.

KLK's earth rod electrodes consist of a high strength steel core with a copper coating that is 99.9% pure electrolytic copper that is molecularly bonded to the steel assuring a non-separable, atomic interlock between the two. This production method allows to get earthing rods with high mechanical strength and corrosion resistance because:

- * Regarding the corrosion resistance against the soil chemical agents their performance is comparable to 99.9% pure copper.
- * Their mechanical performance is like a solid steel rod.
- * Because of the atomic interlock between both copper and steel, not internal corrosion exists.

Earth electrode resistance

In general, earthing resistance is:

- * Greater as the soil resistivity increases
- * Lower as the length of the electrodes increases

Because of the high soil resistivity, earthing currents cause a great voltage drop and 90% of this voltage drop occurs around the electrode, practically in a radius of about 1.80 m from it.

Thus, to get a good earth the following factors must be taken into account:

- * Soil resistivity decreases with moisture, which mainly depends on the depth.
- * The longer is the rod electrode most likely is to reach permanent moisture unaffected by seasonal changes.
- * When soil conditions make deep driving difficult, parallel rod electrodes may be used. To get the best results earth rods must be spaced at least equal to the driven depth but not significant decrease is achieved by spacing them greater than twice their driven depth.

"UNESA" EARTH COPPERBOND ROD ELECTRODES

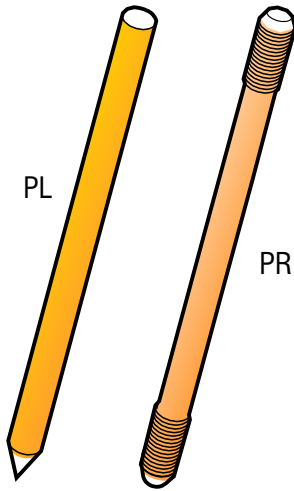

TYPE **RU 6 501**

UNESA RU 6 501 F Publication specify the main characteristics of the copperbonded rod electrodes to be used in electrical installations as well as the tests to ascertain compliance with it.

Identification Mark	Finishig	Thread	Length x Nomial Dia. (mm)	Shank Dia. (mm)
KLK PL 20 RU	Unthreaded		2000 x 14.6	14.6
KLK PR 15 RU KLK PR 20 RU	Threaded Threaded	M 16 x 2 M 16 x 2	1500 x 14.6 2000 x 14.6	14.6 14.6

The identification mark is stamped close to the rod top end.

The rod's diameter is measured over the copper coating; tolerance in diameter is +0.2/-0.1 mm.

The tolerance in the rod's length is ± 5 mm.

Threads are cold-rolled after the copper coating operation.

The rod steel core must not appear at any point in the threads.

MATERIALS

Core.- The steel core is a carbon steel with a Brinell hardness between 180 & 220 H. Its contents of Phosphorous and Sulphur must not be greater than 0.40%.

Coating.- 99.9% pure electrolytic copper as specified in UNE 20 003 Standard. The minimum average copper thickness at any rod section shall be 0.300 mm and at any point the copper thickness shall not be less than 0.270 mm.



OTHER COPPERBONDED ROD ELECTRODES

KLK copperbonded rods are manufactured from a high strength steel core with a 99.9 pure electrolytic copper molecularly bonded onto the steel core.

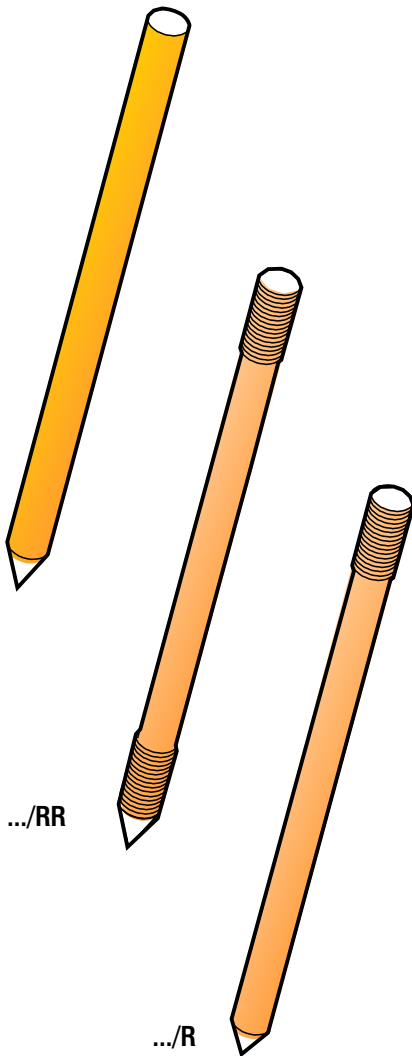

TYPE **NU**

High quality rods, copper average thickness 300 micron.

Cat. Ref.	Length x Nomial Dia. (mm)	Shank Dia. (Mm)
15 NU 146	1500 x 16	14.6
20 NU 146	2000 x 16	14.6
25 NU 146	2500 x 16	14.6
30 NU 146	3000 x 16	14.6
15 NU 183	1500 x 20	18.3
20 NU 183	2000 x 20	18.3
25 NU 183	2500 x 20	18.3
30 NU 183	3000 x 20	18.3

TYPE **J**

According to ANSI/UL 467 minimum copper thickness 250 micron

Cat. Ref.	Length x Nomial Dia. (mm)	Shank Dia. (Mm)
J-15 58	1500 x 5/8"	14.3
J-20 58	2000 x 5/8"	14.3
J-25 58	2500 x 5/8"	14.3
J-30 58	3000 x 5/8"	14.3
J-15 34	1500 x 3/4"	17.3
J-20 34	2000 x 3/4"	17.3
J-25 34	2500 x 3/4"	17.3
J-30 34	3000 x 3/4"	17.3

For rods threaded at the top end, add "**R**" to the Cat. Ref and "**RR**" for rods threaded at both ends

NOTE: Nominal and shank diameters do not correspond due to the thread rolling process used .

ALL KLK EARTH RODS ARE STAMPED WITH THE CAT. REF. CLOSE TO THE ROD TOP END.

TYPE **ST**

Commercial quality rods, average copper thickness 150 micron.

Cat. Ref.	Length x Nomial Dia. (mm)	Shank Dia. (Mm)
15 ST 143	1500 x 16	14.3
20 ST 143	2000 x 16	14.3
25 ST 143	2500 x 16	14.3
30 ST 143	3000 x 16	14.3

OTHER ROD SIZES (LENGTH & DIAMETER) AND COPPER THICKNES COATING MADE TO ORDER AS SPECIAL ITEMS

ACCESSORIES

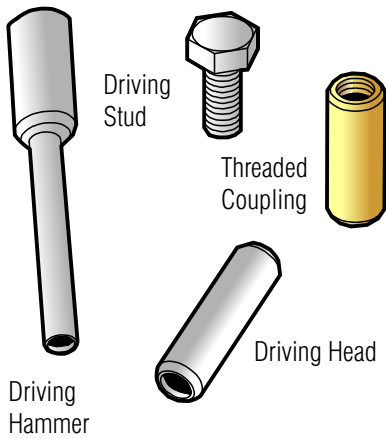

- Driving Hammer 10 Kg.
- Driving Head
- Driving Stud **T-16**
- Driving Stud **T-58**
- Coupling **M-16/Brass**
- Coupling **M-58/Brass**
- Coupling **M-16/Cu-Al**
- Coupling **M-58/Cu-Al**
- Driving Stud **T-20**
- Driving Stud **T-34**
- Coupling **M-20/Brass**
- Coupling **M-34/Brass**
- Coupling **M-20/Cu-Al**
- Coupling **M-34/Cu-Al**

Earth rods driving

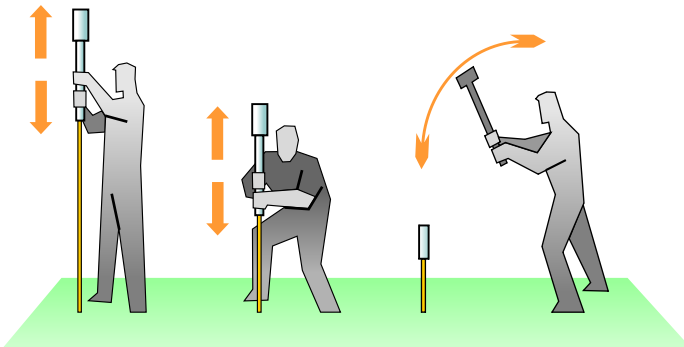

(1) When driving threaded rods, use a coupling and a driving stud on the rod head to prevent rod's thread damage.

When a pneumatic hammer is not available unthreaded rods (1), may be driven using the KLK's accessories as follows:

- * First clubbing with the driving hammer as in the far left image.
- * When the rod length is too short to continue this way, change it for a standard mallet and use the driven head to prevent rod's head damage.

ZINC RODS (Cathodic protection)

CAT. REF.	10 Zn 30	15 Zn 35
A	Ø 13	Ø 12
B	Ø 30	Ø 35
C	1000	1500
D	50	60
L	1081	1597

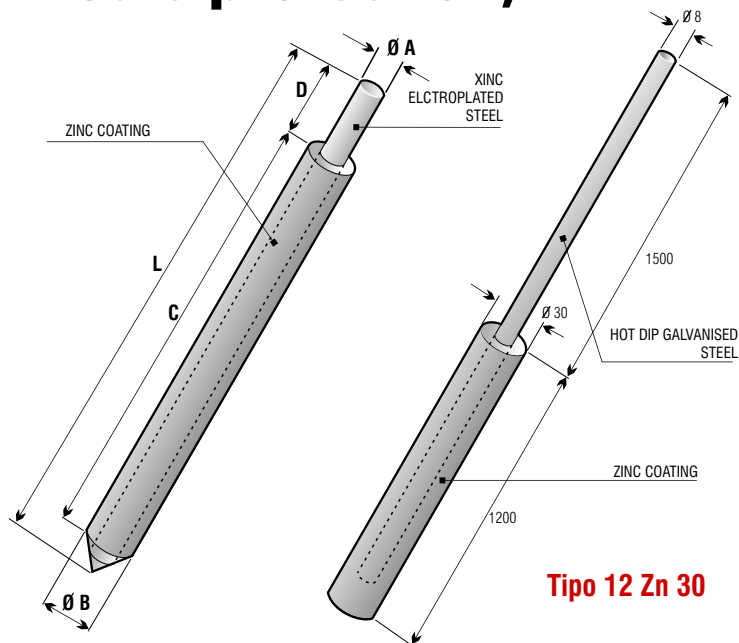

Tipo 12 Zn 30

EARTHING RODS CLAMPS

- * Designed to ensure a reliable connection with the earthing rods.
- * High strength and corrosion resistance copper alloy body.
- * Press-forged body.
- * Zinc electroplated steel or stainless steel hardware.(1)

KR-30

KB

KR

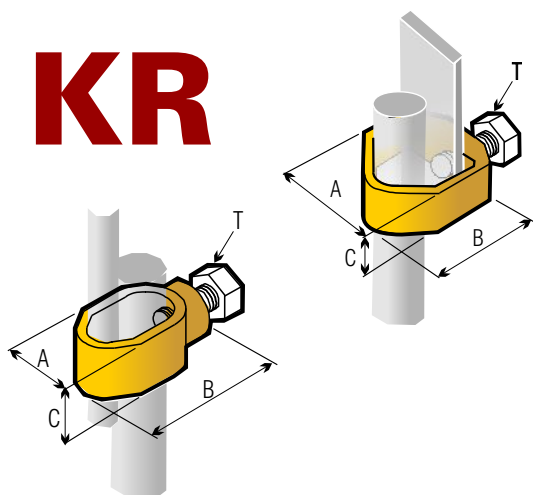

KU

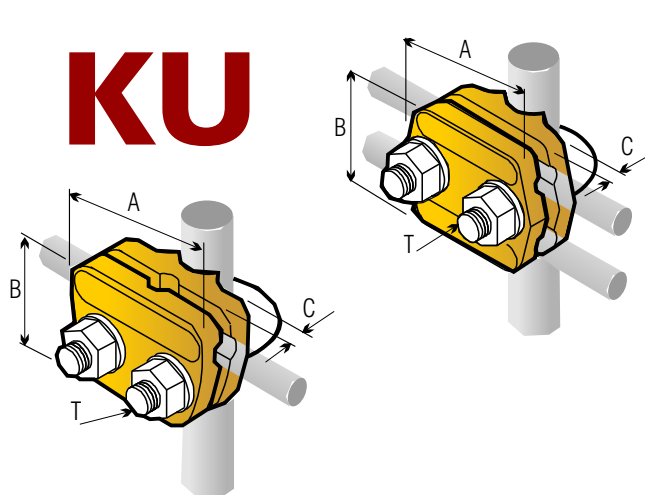

CAT. REF.	Max. Rod size (mm.)	CONDUCTOR RANGE				DIMENSIONS			
		Strand mm. ²		Wire Ø mm.		A	B	C	T
		Min.	Max.	Min.	Max.				
KR-1	16	10	70	4	11	23	38	18	M8
KR-2	20	25	95	6	13	28	43	20	M10
KR-30	20				30x6	42	40	20	M10
KU-1616	15	16	35	4	6	40	24	5	M8
KU-1625	16	25	70	6	11	50	38	7	M10
KU-2025	20	25	70	6	11	50	38	7	M10
KU-1663	16 y 20	70	95	10	13	52	37	7	M10
KU-2012	20	95	185	10	18	65	45	9	M10
KB-1625	16 y 20	25	70	6	11	50	40	6	M10
KB-1663	16 y 20	70	95	10	13	52	43	7	M10
KB-2012	20	95	185	13	18	65	57	10	M10

(1) For stainless steel hardware add "lx" to the Cat. Ref.

MISCELLANEOUS CLAMPS

- * High strength and corrosion resistance copper alloy body.
- * Press-forged body.
- * Zinc electroplated steel or stainless steel hardware.(1)

KBL

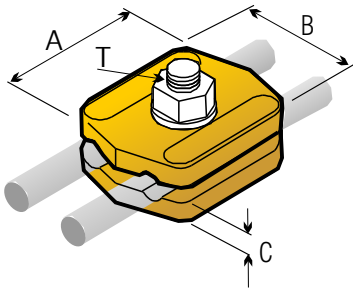

KBH

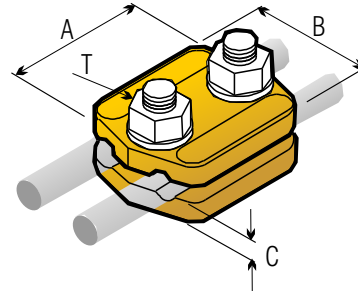

CAT. REF.	CONDUCTOR RANGE				DIMENSIONS			
	Strand mm. ²		Wire Ø mm.		A	B	C	T
	Min.	Max.	Min.	Max.				
KBL-25	25	70	6	11	50	40	7	M8x35
KBL-63	70	95	11	13	54	45	8.5	M10x45
KBL-125	95	185	13	18	65	57	12.5	M10x55
KBH-25	25	70	6	11	50	40	7	M8x35
KBH-63	70	95	11	13	54	45	8.5	M10x45
KBH-125	95	185	13	18	65	57	12.5	M10x55

(1) For stainless steel hardware add "lx" to the Cat. Ref.

KZ

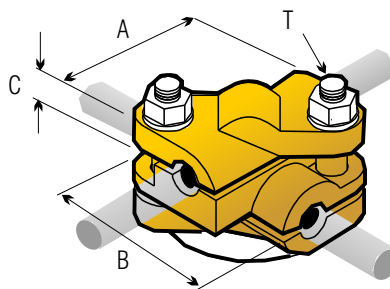

CAT. REF.	CONDUCTORS RANGE				DIMENSIONS			
	Strand mm. ²		Wire Ø mm.		A	B	C	T
	Min.	Max.	Min.	Max.				
KZ-25	25	70	6	11	44	44	7	M8
KZ-63	70	95	11	13	62	62	12	M10
KZ-100	95	185	12	28	62	62	12	M10

(1) For stainless steel hardware add "lx" to the Cat. Ref.

MISCELLANEOUS CLAMPS (cont.)

KDP

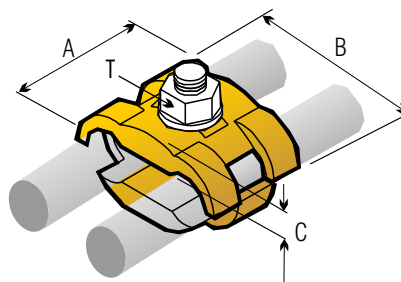

CAT. REF.	CONDUCTORS RANGE				DIMENSIONS			
	Strand mm. ²		Wire Ø mm.		A	B	C	T
	Min.	Max.	Min.	Max.				
KDP-50	16	50	4	9	25	33	5.5	M8x30
KDP-95	25	95	6	13	30	42	6.5	M8x35
KDP-150	35	150	7	16	35	52	7	M10x40
KDP-240	95	240	12	21	40	62	12	2-M8x45
KDP-16/150	16	150	4	16	50	53	11	2-M8x45

(1) For stainless steel hardware add "lx" to the Cat. Ref.

KX

KXP

KXR

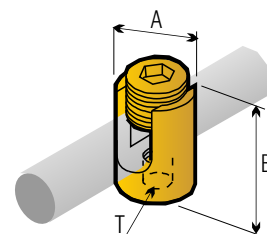
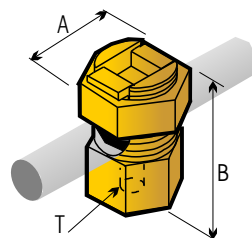
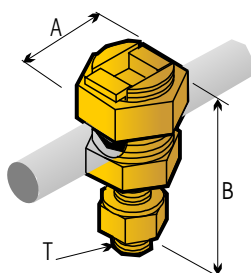

CAT. REF.	CONDUCTORS RANGE				DIMENSIONS		
	Strand mm. ²		Wire Ø mm.		A	B	T
	Min.	Max.	Min.	Max.			
KX-10	10	35	4	8	18	47	M8x20
KX-25	25	70	6	11	24	56	M10x25
KX-63	70	95	10	13	32	65	M12x25
KX-100	95	185	12	18	40	78	M14x25
KXP-10	10	35	4	8	18	26	M6x7
KXP-25	25	70	6	11	24	34	M6x11
KXP-63	70	95	10	13	32	43	M8x13
KXP-100	95	185	12	18	40	56	M10x15
KXR-10	10	35	4	8	18	22	M6x6
KXR-25	25	70	6	11	22	27	M6x6
KXR-63	70	120	10	15	26	37	M8x10
KXR-100	95	185	12	18	30	42	M8x10

KM

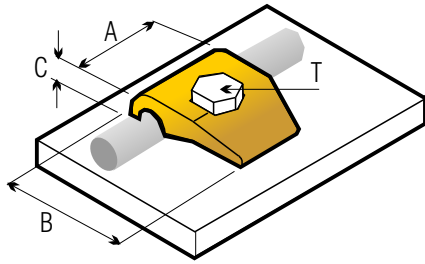

KML

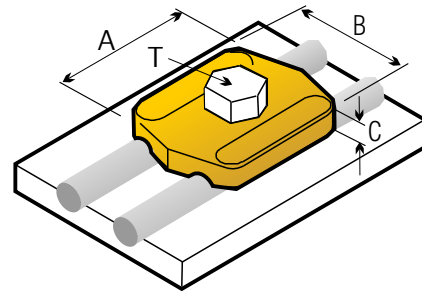

CAT. REF.	CONDUCTORS RANGE				DIMENSIONS			
	Strand mm. ²		Wire Ø mm.		A	B	C	T
	Min.	Max.	Min.	Max.				
KM-25	25	70	6	11	25	40	7.5	M8x30
KM-63	70	95	11	13	35	45	11	M10x35
KM-100	95	185	12	18	40	55	15	M10x50
KML-25	25	70	6	11	50	40	7	M8x35
KML-63	70	95	11	13	54	45	8.5	M10x45
KML-125	95	185	13	18	65	57	12.5	M10x55

For stainless steel hardware add "lx" to the Cat. Ref.

PBL

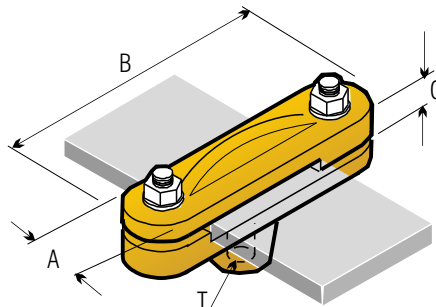

CAT. REF	ACCEPTABLE PLATE WIDTH	DIMENSIONS			
		A	B	C	T
PBL-30	30	20	60	7.5	M8x12
PBL-40	40	20	70	7.5	M8x12
PBL-50	50	25	80	8	M10x15
PBL-60	60	30	95	9	M10x15
PBL-70	70	30	105	10	M10x15
PBL-80	80	30	115	11	M10x15
PBL-90	90	40	135	11	M10x15
PBL-100	100	40	145	12	M10x15
PBL-110	110	40	155	12	M10x15
PBL-120	120	50	170	14	M10x15
PBL-130	130	60	180	14	M10x15

For stainless steel hardware add "lx" to the clamp Cat. Ref.

MISCELLANEOUS CLAMPS (cont.)

GK

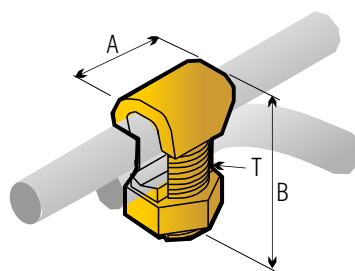

CAT. REF.	CONDUCTORS RANGE				DIMENSIONS		
	Strand mm. ²		Wire Ø mm.		A	B	T
	Min.	Max.	Min.	Max.			
GK-35	16	35	5.5	6.5	15	35	M15
GK-63	35	70	7	9.5	22	40	M20
GK-120	50	120	10	10	30	50	M27

TERMINALS

TK.T

TK.P

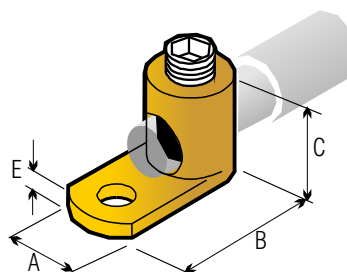
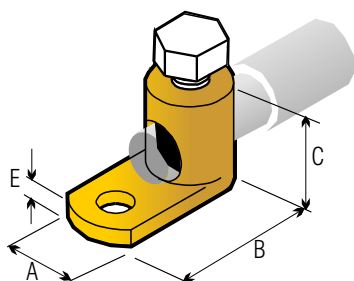

CAT. REF.	CONDUCTORS RANGE		Screw Hole Dia. (mm)	DIMENSIONS			
	Strand mm. ²			A	B	C	E
	Min.	Max.					
TK 25 T		25	6.5	14	28	18	3
TK 50 T		50	8.5	19	38	24	4
TK 150 T		150	10.5	24	50	32	5
TK 300 T		300	12.5	35	76	44	7
TK 25 P		25	6.5	14	28	18	3
TK 50 P		50	8.5	19	38	24	4
TK 150 P		150	10.5	24	50	32	5
TK 300 P		300	12.5	35	76	44	7

For stainless steel hardware add "lx" to the Cat. Ref.

DISCONNECTING LINKS

PT

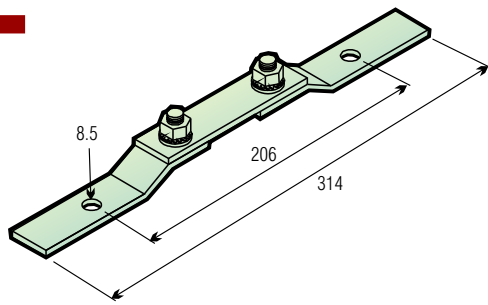

CAT. REF.	COPPER BAR DIMENSIONS
PT-3	25 x 3
PT-4	25 x 4
PT-5	25 x 5
PT-6	25 x 6

Consist of a copper bar with zinc electroplated brass hardware.

EARTHING BARS

EC

- ◆ KBH clamps with zinc electroplated steel or Stainless steel hardware.(1)
- ◆ Copper electroplated bar

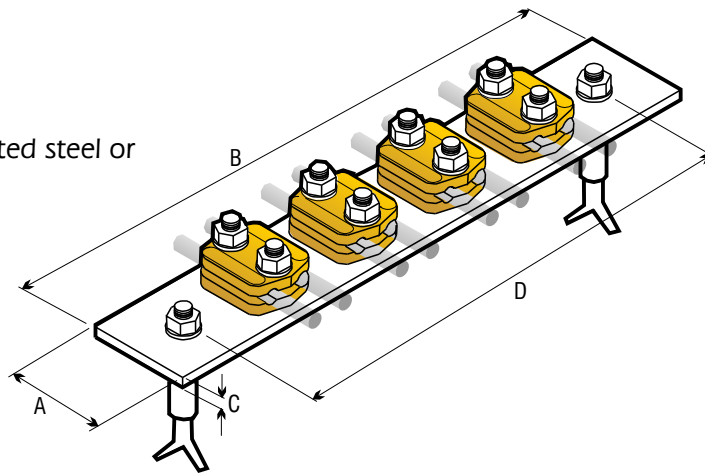

CAT. REF.	No. of Clamps	CONDUCTORS RANGE		DIMENSIONS			
		Min.	Max.	A	B	C	D
EC 70-2	2	25	70	60	195	6	170
EC 70-3	3				265		240
EC 70-4	4				335		310
EC 70-5	5				405		380
EC 70-6	6				475		450
EC 100-2	2				70		95
EC 100-3	3	265	240				
EC 100-4	4	335	310				
EC 100-5	5	405	380				
EC 100-6	6	475	450				
EC 200-2	2	95	185	60		195	
EC 200-3	3				265	240	
EC 200-4	4				335	310	
EC 200-5	5				405	380	
EC 200-6	6				475	450	

For stainless steel hardware add "lx" to the Earthing Bar Cat. Ref.



EARTH INSPECTION PITS

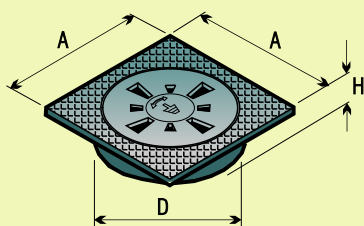

METALLIC PITS

AC-M

CAT. REF.	A	D	H	MATERIAL
AC-M 150 AL	210	170	48	Aluminium Foundry
AC-M 200 FE	245	210	115	Iron Foundry

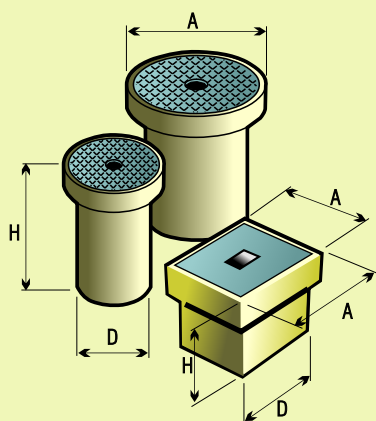

POLYESTER PITS

AC-CP (Round)

AC-RP (Square)

CAT. REF.	D	A	H	Wall thick.
AC-CP 20	200	285	500	3
AC-CP 30	300	400	520	3
AC-RP 40	365	450	490	5

Above products are bottomless.

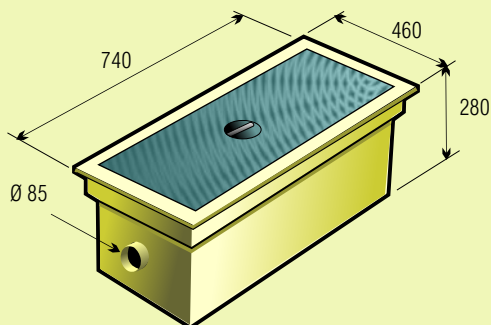

POLYESTER RECTANGULAR EARTHING PIT AC-RP 60

This product's got a draining bottom suitable for fixing disconnecting links or earthing bars.



Electro Materiales, s.a.

Camino de la Peñona 38B - 33211 GIJON - SPAIN / P.O. BOX 333 - 33206 - Tel. (34) 98 532 18 50 - Fax (34) 98 531 28 20
E-mail: export@klk.es Web: www.klk.es

SUBSIDIARIES:

KLK-USA:

P.O. Box 5190 / 2881 N.E. 7th Avenue / Pompano Beach, Fl 33064 USA / Tel. (1) 954 942 8321 / Fax (1) 954 785 1262

EKE Electra - KLK - Europe:

Z.A. de l'Europe. 6 rue de l'Orge / 68920 Wintzenheim Logelbach FRANCE / Tel (33) 03 892 01730 / Fax (33) 03 892 01731